

# Wavelets and filterbanks

Mallat 2009, Chapter 7

# Outline

- Wavelets and Filterbanks
- Biorthogonal bases
- The dual perspective: from FB to wavelet bases
  - Biorthogonal FB
  - Perfect reconstruction conditions
- Separable bases (2D)
- Overcomplete bases
  - Wavelet frames (algorithme à trous, DDWF)
  - Curvelets

# Wavelets and Filterbanks

## Wavelet side

- **Scaling function**
  - Design (from multiresolution priors)
  - Signal approximation
  - Corresponding filtering operation
    - Condition on the filter  $h[n]$  → Conjugate Mirror Filter (CMF)
- **Corresponding wavelet families**

## Filterbank side

- **Perfect reconstruction conditions (PR)**
  - Reversibility of the transform
- **Equivalence with the conditions on the wavelet filters**
  - Special case: CMFs → Orthogonal wavelets
  - General case → Biorthogonal wavelets

# Wavelets and filterbanks

- The decomposition coefficients in a wavelet orthogonal basis are computed with a fast algorithm that cascades discrete convolutions with  $h$  and  $g$ , and subsample the output
- Fast orthogonal WT

$$f(t) = \sum_n a_0[n] \varphi(t-n) \in V_0$$

Since  $\{\varphi(t-n)\}_{n \in \mathbb{Z}}$  is an orthonormal basis

$$a_0[n] = \langle f(t), \varphi(t-n) \rangle = \int_{-\infty}^{+\infty} f(t) \varphi^*(t-n) dt = \int_{-\infty}^{+\infty} f(t) \bar{\varphi}^*(n-t) dt = f * \bar{\varphi}(n)$$

$$\bar{\varphi}(t) = \varphi(-t)$$

## Linking the domains

$$z = e^{j\omega}$$

$$\hat{f}(\omega) = \hat{f}(e^{j\omega}) \leftrightarrow f(z)$$

$$\hat{f}(\omega + \pi) = \hat{f}(e^{j(\omega + \pi)}) = \hat{f}(-e^{j\omega}) \leftrightarrow f(-z)$$

$$\hat{f}(-\omega) = \hat{f}(e^{-j\omega}) \leftrightarrow f(z^{-1})$$

$$\hat{f}^*(\omega) = \hat{f}(-\omega) \leftrightarrow f(z^{-1})$$

Switching between the  
Fourier and the z-domain

$$f[n] \leftrightarrow f(z) = \sum_{k=-\infty}^{+\infty} f[k]z^{-k}$$

$$f[n-1] \leftrightarrow z^{-1}f(z) \quad \text{unit delay}$$

$$f[-n] \leftrightarrow f(z^{-1}) \quad \text{reverse the order of the coefficients}$$

$$(-1)^n f[n] \leftrightarrow f(-z) \quad \text{negate odd terms}$$

Switching between the time  
and the z-domain

## Fast orthogonal wavelet transform

- Fast FB algorithm that computes the orthogonal wavelet coefficients of a discrete signal  $a_0[n]$ . Let us define

$$f(t) = \sum_n a_0[n] \varphi(t - n) \in V_0$$

Since  $\{\varphi(t - n)\}_{n \in \mathbb{Z}}$  is orthonormal, then

$$a_0[n] = \langle f(t), \varphi(t - n) \rangle = f * \bar{\varphi}(n)$$

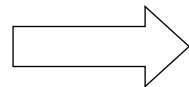

$$a_j[n] = \langle f, \varphi_{j,n} \rangle \text{ since } \varphi_{j,n} \text{ is an orthonormal basis for } V_j$$
$$d_j[n] = \langle f, \psi_{j,n} \rangle$$

- A fast wavelet transform decomposes successively each approximation  $PV_j f$  in the coarser approximation  $PV_{j+1} f$  plus the wavelet coefficients carried by  $PW_{j+1} f$ .*
- In the reconstruction,  $PV_j f$  is recovered from  $PV_{j+1} f$  and  $PW_{j+1} f$  for decreasing values of  $j$  starting from  $J$  (decomposition depth)*

# Fast wavelet transform

- Theorem 7.7

- At the decomposition

$$a_{j+1}[p] = \sum_{n=-\infty}^{+\infty} h[n-2p]a_j[n] = a_j * \bar{h}[2p] \quad (1)$$

$$d_{j+1}[p] = \sum_{n=-\infty}^{+\infty} g[n-2p]a_j[n] = a_j * \bar{g}[2p] \quad (2)$$

- At the reconstruction

$$a_j[p] = \sum_{n=-\infty}^{+\infty} h[p-2n]a_{j+1}[n] + \sum_{n=-\infty}^{+\infty} g[p-2n]d_{j+1}[n] = \check{a}_{j+1} * h[n] + \check{d}_{j+1} * g[n] \quad (4)$$

$$\check{x}[n] = \begin{cases} x[p] & n = 2p \\ 0 & n = 2p + 1 \end{cases}$$

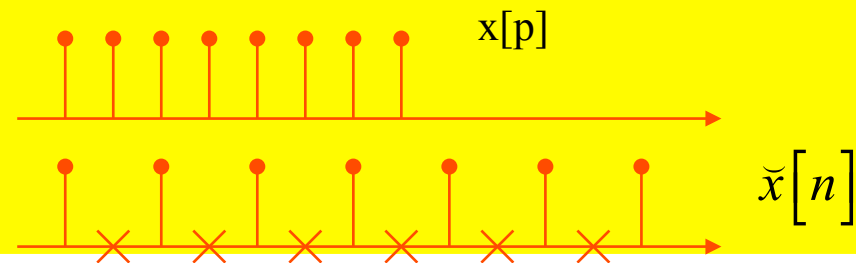

## Proof: decomposition (1)

$$\varphi_{j+1}[p] \in V_{j+1} \subset V_j \rightarrow \varphi_{j+1}[p] = \sum_n \langle \varphi_{j+1}[p], \varphi_j[n] \rangle \varphi_j[n] \quad (\text{b})$$

but

$$\langle \varphi_{j+1}[p], \varphi_j[n] \rangle = \int \frac{1}{\sqrt{2^{j+1}}} \varphi\left(\frac{t-2^{j+1}p}{2^{j+1}}\right) \frac{1}{\sqrt{2^j}} \varphi^*\left(\frac{t-2^j n}{2^j}\right) dt \quad (\text{a})$$

let

$$t' = 2^{-j}t - 2p \rightarrow t = 2^j t' + 2^{j+1}p \rightarrow t - 2^{j+1}p = 2^j t' \rightarrow \frac{t-2^{j+1}p}{2^{j+1}} = \frac{t'}{2}$$

then

$$\varphi\left(\frac{t-2^{j+1}p}{2^{j+1}}\right) = \varphi\left(\frac{t'}{2}\right)$$

$$\varphi^*\left(\frac{t-2^j n}{2^j}\right) = \varphi^*(t' + 2p - n)$$

$$\frac{t'}{2} = \frac{t}{2^{j+1}} - p \rightarrow \frac{t}{2^{j+1}} = \frac{t'}{2} + p \rightarrow \frac{t}{2^j} = t' + 2p$$

replacing into (a)

$$(3) \quad \langle \varphi_{j+1}[p], \varphi_j[n] \rangle = \int \frac{1}{\sqrt{2}} \varphi\left(\frac{t'}{2}\right) \varphi^*(t' + 2p - n) dt' = \left\langle \frac{1}{\sqrt{2}} \varphi\left(\frac{t}{2}\right), \varphi(t + 2p - n) \right\rangle = h[n - 2p]$$

thus (b) becomes

$$\boxed{\varphi_{j+1}[p] = \sum_n h[n - 2p] \varphi_j[n]}$$



## Proof: decomposition (2) qui

- Coming back to the projection coefficients

$$\begin{aligned} a_{j+1}[p] &= \langle f, \varphi_{j+1,p} \rangle = \left\langle f, \sum_n h[n-2p] \varphi_{j,n} \right\rangle = \int_{-\infty}^{+\infty} f \sum_n h[n-2p] \varphi_{j,n}^* dt = \\ &= \sum_n h[n-2p] \int_{-\infty}^{+\infty} f(t) \varphi_{j,n}^*(t) dt = \sum_n h[n-2p] \langle f, \varphi_{j,n} \rangle = \sum_n h[n-2p] a_j[n] \rightarrow \\ &\boxed{a_{j+1}[p] = a_j * \bar{h}[2p]} \end{aligned}$$

- Similarly, one can prove the relations for both the details and the reconstruction formula

## Proof: decomposition (3)

- Details

$$\psi_{j+1,p} \in W_{j+1} \subset V_j \rightarrow \psi_{j+1,p} = \sum_n \langle \psi_{j+1,n}, \varphi_{j,n} \rangle \varphi_{j,n}$$

$$t' = 2^{-j}t - 2p \rightarrow$$

(3bis)  $\langle \psi_{j+1,n}, \varphi_{j,n} \rangle = \left\langle \frac{1}{\sqrt{2}} \psi \left( \frac{t}{2} \right), \varphi(t - n + 2p) \right\rangle = g[n - 2p] \rightarrow$

$$\psi_{j+1,p} = \sum_n g[n - 2p] \varphi_{j,n} \rightarrow$$

$$\langle f, \psi_{j+1,n} \rangle = \sum_n g[n - 2p] \langle f, \varphi_{j,n} \rangle \rightarrow$$

$$d_{j+1}[p] = \sum_n g[n - 2p] a_j[n]$$

## Proof: Reconstruction

Since  $W_{j+1}$  is the orthonormal complement of  $V_{j+1}$  in  $V_j$ , the union of the two respective basis is a basis for  $V_j$ . Hence

$$V_j = V_{j+1} \oplus W_{j+1} \rightarrow \varphi_{j,p} = \sum_n \langle \varphi_{j,p}, \varphi_{j+1,n} \rangle \varphi_{j+1,n} + \sum_n \langle \varphi_{j,p}, \psi_{j+1,n} \rangle \psi_{j+1,n}$$

but  $\langle \varphi_{j,p}, \varphi_{j+1,n} \rangle = h[p - 2n]$  (see (3) and (3bis), the analogous one for g)

$$\langle \varphi_{j,p}, \psi_{j+1,n} \rangle = g[p - 2n]$$

thus

$$\varphi_{j,p} = \sum_n h[p - 2n] \varphi_{j+1,n} + \sum_n g[p - 2n] \psi_{j+1,n}$$

Taking the scalar product with f at both sides:

$$a_j[p] = \sum_{n=-\infty}^{+\infty} h[p - 2n] a_{j+1}[n] + \sum_{n=-\infty}^{+\infty} g[p - 2n] d_{j+1}[n] = \check{a}_{j+1} * h[n] + \check{d}_{j+1} * g[n]$$

CVD

$$\check{x}[n] = \begin{cases} x[p] & n = 2p \\ 0 & n = 2p + 1 \end{cases}$$

## Graphically

$$a_j[p] = \sum_n h[p-2n]a_{j+1}[n] = \sum_n a_{j+1}[n]h[p-2n]$$

$$a_j[0] = \sum_n h[-2n]a_{j+1}[n] = \sum_n a_{j+1}[n]h[-2n]$$

Let's assume that  $h$  is symmetric

$$a_j[0] = \sum_n a_{j+1}[n]h[2n]$$

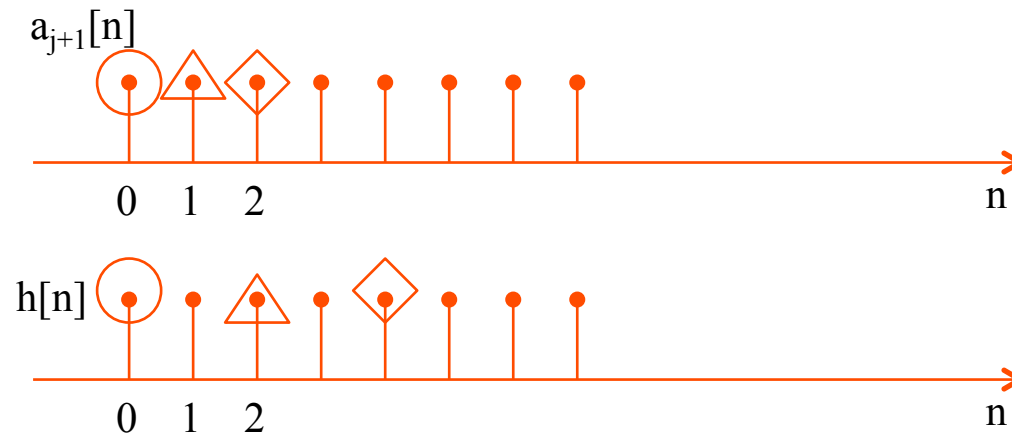

# Graphically

$\tilde{a}_{j+1}[n]$

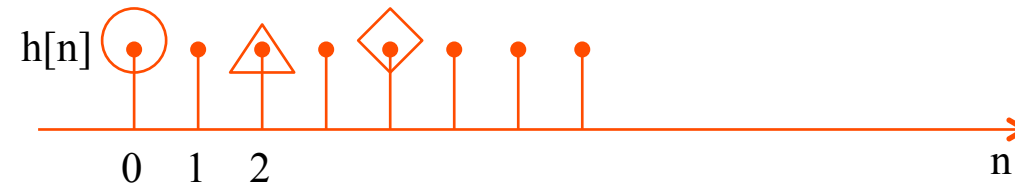
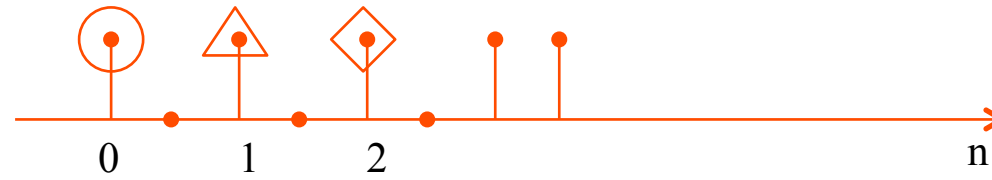

$$a_j[0] = \sum_n a_{j+1}[n] h[2n] = \sum_n \tilde{a}_{j+1}[n] h[n]$$

## Summary

$$a_{j+1}[p] = a_j * \bar{h}[2p]$$

- The coefficients  $a_{j+1}$  and  $d_{j+1}$  are computed by taking every other sample of the convolution of  $a_j$  with  $\bar{h}$  and  $\bar{g}$  respectively.
- The filter  $\bar{h}$  *removes* the higher frequencies of the inner product sequence  $a_j$ , whereas  $\bar{g}$  is a high-pass filter that *collects* the remaining highest frequencies.
- The reconstruction is an interpolation that inserts zeroes to expand  $a_{j+1}$  and  $d_{j+1}$  and filters these signals, as shown in Figure.

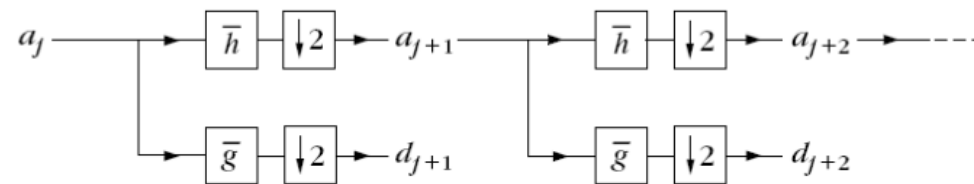

(a)

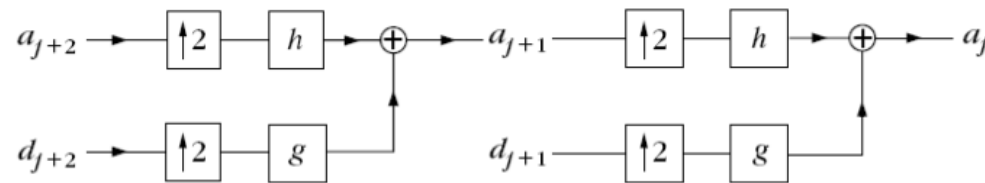

(b)

# Filterbank implementation

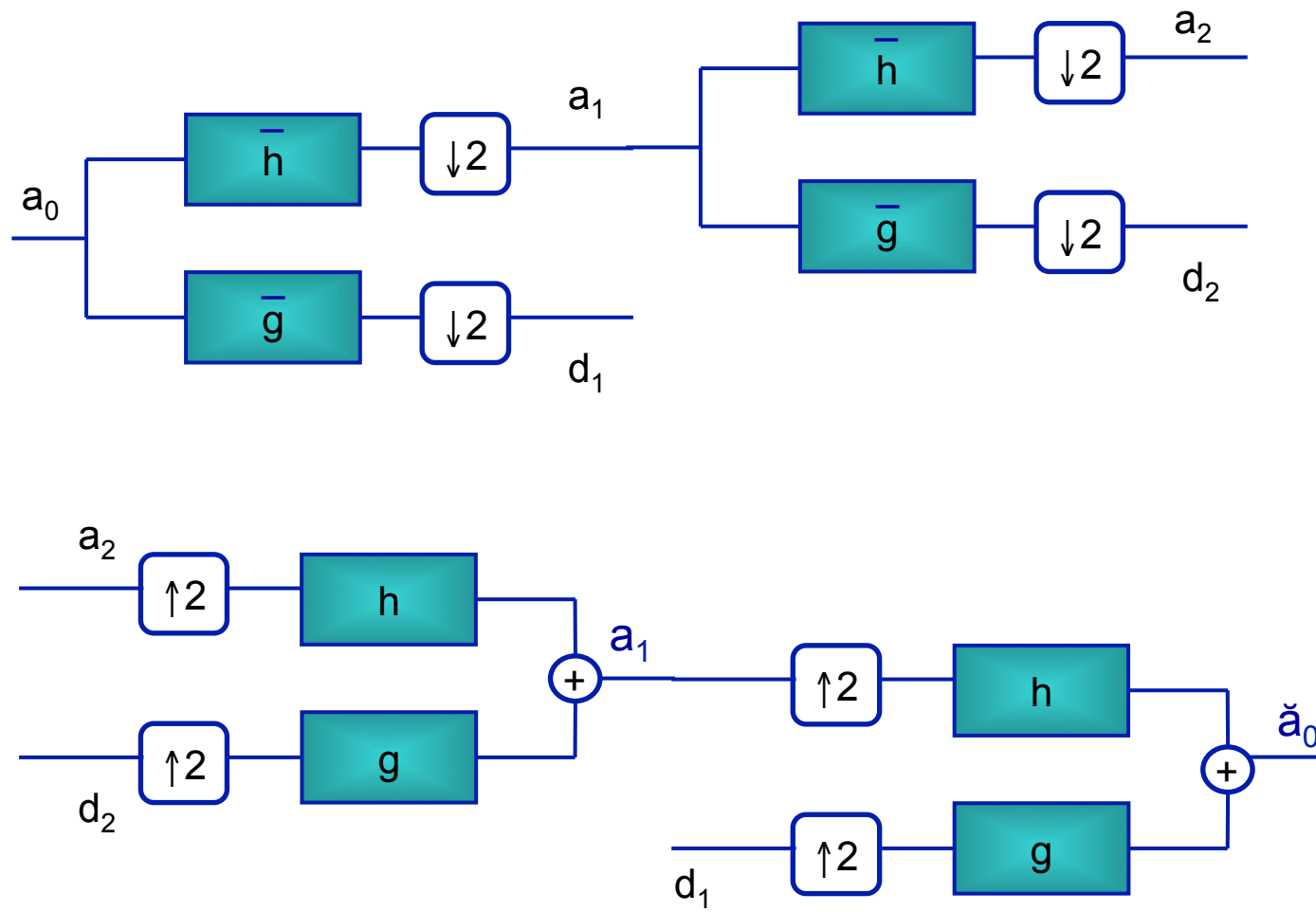

# Fast DWT

- Theorem 7.10 proves that  $a_{j+1}$  and  $d_{j+1}$  are computed by taking every other sample of the convolution on  $a_j$  with  $\bar{h}$  and  $\bar{g}$  respectively
- The filter  $h$  removes the higher frequencies of the inner product and the filter  $g$  is a band-pass filter that collects such residual frequencies
- An orthonormal **wavelet representation** is composed of wavelet coefficients at scales

$$1 \leq 2^j \leq 2^J$$

plus the remaining approximation at scale  $2^J$

$$\left[ \left\{ d_j \right\}_{1 \leq j \leq J}, a_J \right]$$



## Summary

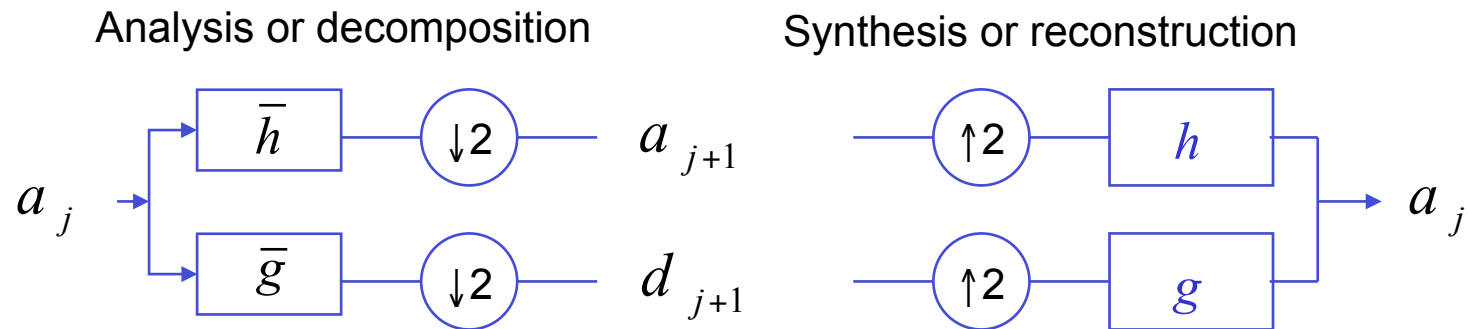

**Theorem 7.2** (Mallat&Meyer) and **Theorem 7.3** [Mallat&Meyer] 

$$\forall \omega \in \mathbb{R}, \quad |\hat{h}(\omega)|^2 + |\hat{h}(\omega + \pi)|^2 = 2$$

and

$$\hat{h}(0) = \sqrt{2}$$

$$\hat{g}(\omega) = e^{-j\omega} \hat{h}^*(\omega + \pi) \Leftrightarrow g[n] = (-1)^{1-n} h[1-n]$$

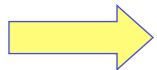

**The fast orthogonal WT is implemented by a filterbank that is completely specified by the filter  $h$ , which is a CMF**  
**The filters are the same for every  $j$**

## Filter bank perspective

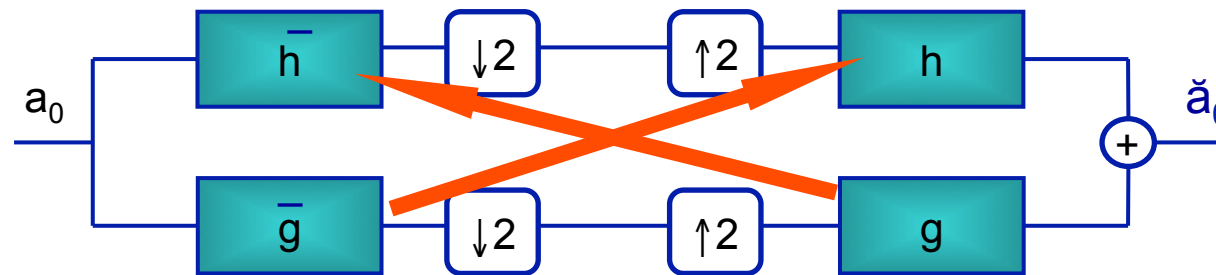

Taking  $h[n]$  as reference (which amounts to choosing **the synthesis low-pass filter**) the following relations hold for an orthogonal filter bank:

$$\bar{h}[n] = h[-n]$$

$$g[n] = (-1)^{1-n} h[1-n] = (-1)^{1-n} \bar{h}[n-1]$$

$$\bar{g}[n] = g[-n] = (-1)^{-(1-n)} h[-(1-n)]$$

neglecting the unitary shift, as usually done in applications

$$g[n] = (-1)^{-n} h[-n] = (-1)^{-n} \bar{h}[n]$$

$$\bar{g}[n] = g[-n] = (-1)^n h[n]$$

# Finite signals

- Issue: signal extension at borders
- Possible solutions:
  - Periodic extension
    - Works with any kind of wavelet
    - Generates large coefficients at the borders
  - Symmetry/antisymmetric extension, depending on the wavelet symmetry
    - More difficult implementation
    - Haar filter is the only symmetric filter with compact support
  - Use different wavelets at boundary (boundary wavelets)
  - Implementation by *lifting steps*

## Wavelet graphs

The graphs of  $\phi$  and  $\psi$  are computed numerically with the inverse wavelet transform. If  $f = \phi$ , then  $a_0[n] = \delta[n]$  and  $d_j[n] = 0$  for all  $L < j \leq 0$ . The inverse wavelet transform computes  $a_L$  and (7.111) shows that

$$N^{1/2} a_L[n] \approx \phi(N^{-1}n).$$

If  $\phi$  is regular and  $N$  is large enough, we recover a precise approximation of the graph of  $\phi$  from  $a_L$ .

Similarly, if  $f = \psi$ , then  $a_0[n] = 0$ ,  $d_0[n] = \delta[n]$ , and  $d_j[n] = 0$  for  $L < j < 0$ . Then  $a_L[n]$  is calculated with the inverse wavelet transform and  $N^{1/2} a_L[n] \approx \psi(N^{-1}n)$ . The Daubechies wavelets and scaling functions in Figure 7.10 are calculated with this procedure.

# Orthogonal wavelet representation

- An *orthogonal wavelet representation* of  $a_L = \langle f, \varphi_{L,n} \rangle$  is composed of wavelet coefficients of  $f$  at scales  $2^L < 2^j \leq 2^J$ , plus the remaining approximation at the largest scale  $2^J$  :

$$[\{d_j\}_{L < j \leq J}, a_J].$$

- **Initialization**

- Let  $b[n]$  be the discrete time input signal and let  $N^{-1}$  be the sampling period, such that the corresponding scale is  $2^L = N^{-1}$
- Then:

$$f(t) = \sum_{n=-\infty}^{+\infty} b[n] \phi\left(\frac{t - 2^L n}{2^L}\right) \in \mathbf{V}_L.$$

$N^{-1}$ : discrete sample distance  
 $2^L = N^{-1}$  scale

original continuous time signal      discrete time signal      interpolation function

## Initialization

$$f(t) = \sum_{n=-\infty}^{+\infty} b[n] \phi\left(\frac{t - 2^L n}{2^L}\right) \in \mathbf{V}_L.$$

following the definition:

$N^{-1}$ : discrete sample distance

$2^L = N^{-1}$  scale

$$\varphi_{L,n} = \frac{1}{\sqrt{2^L}} \varphi\left(\frac{t - 2^L n}{2^L}\right) \quad \text{Basis for } \mathbf{V}_L$$

$$2^L = \frac{1}{N} \rightarrow \frac{1}{\sqrt{2^L}} = N^{1/2} = \sqrt{N} \rightarrow \varphi_{L,n} = \sqrt{N} \varphi\left(\frac{t - N^{-1}n}{N^{-1}}\right) \rightarrow \varphi\left(\frac{t - N^{-1}n}{N^{-1}}\right) = \frac{1}{\sqrt{N}} \varphi_{L,n}$$

but

$$f(t) = \sum_{n=-\infty}^{+\infty} b[n] \varphi\left(\frac{t - N^{-1}n}{N^{-1}}\right) = \frac{1}{\sqrt{N}} \sum_{n=-\infty}^{+\infty} b[n] \varphi_{L,n}(t)$$

$$b[n] = \left\langle f, \varphi\left(\frac{t - N^{-1}n}{N^{-1}}\right) \right\rangle = \left\langle f, \frac{1}{\sqrt{N}} \varphi_{L,n} \right\rangle = \frac{1}{\sqrt{N}} a_L[n] \quad a_L[n] = \langle f, \varphi_{L,n} \rangle$$

since

$$a_L[n] = \int_{-\infty}^{+\infty} f(t) \sqrt{N} \varphi\left(\frac{t - N^{-1}n}{N^{-1}}\right) dt \quad \text{by definition, then}$$

$$a_L[n] \approx \sqrt{N} f(N^{-1}n) \quad \text{if } f \text{ is regular, the sampled values can be considered as a local average in the neighborhood of } f(N^{-1}n)$$

## The filter bank perspective

## Perfect reconstruction FB

- **Dual perspective:** given a filterbank consisting of 4 filters, we derive the *perfect reconstruction conditions*

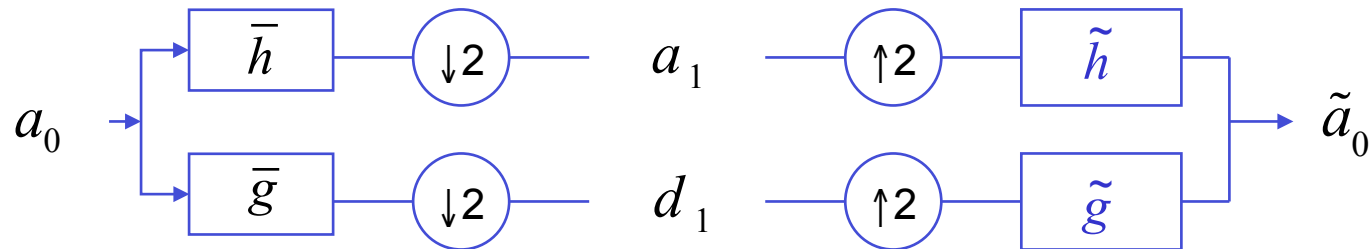

- Goal: determine the conditions on the filters ensuring that

$$\tilde{a}_0 \equiv a_0$$



## PR Filter banks

- The decomposition of a discrete signal in a multirate filter bank is interpreted as an expansion in  $l^2(\mathbb{Z})$

since

$$a_1[l] = a_0 * \bar{h}[2l] = \sum_n a_0[n] \bar{h}[2l - n] = \sum_n a_0[n] h[n - 2l]$$

then

$$a_1[l] = \sum_{n=-\infty}^{+\infty} a_0[n] h[n - 2l] = \langle a_0[n], h[n - 2l] \rangle,$$

$$d_1[l] = \sum_{n=-\infty}^{+\infty} a_0[n] g[n - 2l] = \langle a_0[n], g[n - 2l] \rangle.$$

and the signal is recovered by the reconstruction filter

$$a_0[n] = \sum_{l=-\infty}^{+\infty} a_1[l] \tilde{h}[n - 2l] + \sum_{l=-\infty}^{+\infty} d_1[l] \tilde{g}[n - 2l].$$

thus

$$a_0[n] = \sum_{l=-\infty}^{+\infty} \langle f[k], h[k - 2l] \rangle \tilde{h}[n - 2l] + \sum_{l=-\infty}^{+\infty} \langle f[k], g[k - 2l] \rangle \tilde{g}[n - 2l].$$

dual family of vectors



points to  
biorthogonal  
wavelets

## The two families are biorthogonal

**Theorem 7.13.** If  $h$ ,  $g$ ,  $\tilde{h}$ , and  $\tilde{g}$  are perfect reconstruction filters, and their Fourier transforms are bounded, then  $\{\tilde{h}[n - 2l], \tilde{g}[n - 2l]\}_{l \in \mathbb{Z}}$  and  $\{h[n - 2l], g[n - 2l]\}_{l \in \mathbb{Z}}$  are biorthogonal Riesz bases of  $\ell^2(\mathbb{Z})$ .

Thus, a PR FB projects a discrete time signals over a biorthogonal basis of  $\ell^2(\mathbb{Z})$ .  
If the dual basis is the same as the original basis than the projection is orthonormal.

# Discrete Wavelet basis

- Question: why bother with the construction of wavelet basis if a PR FB can do the same easily?
- Answer: because conjugate mirror filters are most often used in filter banks that cascade several levels of filterings and subsamplings. Thus, it is necessary to understand the behavior of such a cascade

$N^{-1}$ : discrete sample distance

$2^L = N^{-1}$  scale

$$a_L[n] = \langle f, \varphi_{L,n} \rangle \quad \text{discrete signal at scale } 2^L$$

$$\varphi\left(\frac{t - N^{-1}n}{N^{-1}}\right) = \frac{1}{\sqrt{N}} \varphi_{L,n}$$

for depth  $j > L$

$$a_j[l] = a_L \star \bar{\phi}_j[2^{j-L}l] = \langle a_L[n], \phi_j[n - 2^{j-L}l] \rangle$$

$$d_j[l] = a_L \star \bar{\psi}_j[2^{j-L}l] = \langle a_L[n], \psi_j[n - 2^{j-L}l] \rangle.$$

$$\hat{\phi}_j(\omega) = \prod_{p=0}^{j-L-1} \hat{h}(2^p \omega)$$

$$\hat{\psi}_j(\omega) = \hat{g}(2^{j-L-1} \omega) \prod_{p=0}^{j-L-2} \hat{h}(2^p \omega).$$

## Discrete wavelet basis

For conjugate mirror filters, one can verify that this family is an orthonormal basis of  $\ell^2(\mathbb{Z})$ . These discrete vectors are close to a uniform sampling of the continuous time-scaling functions  $\phi_j(t) = 2^{-j/2}\phi(2^{-j}t)$  and wavelets  $\psi_j(t) = 2^{-j/2}\psi(2^{-j}t)$ . When the number  $L - j$  of successive convolutions increases, one can verify that  $\phi_j[n]$  and  $\psi_j[n]$  converge, respectively, to  $N^{-1/2}\phi_j(N^{-1}n)$  and  $N^{-1/2}\psi_j(N^{-1}n)$ .

The factor  $N^{-1/2}$  normalizes the  $\ell^2(\mathbb{Z})$  norm of these sampled functions. If  $L - j = 4$ , then  $\phi_j[n]$  and  $\psi_j[n]$  are already very close to these limit values. Thus, the impulse responses  $\phi_j[n]$  and  $\psi_j[n]$  of the filter bank are much closer to continuous time-scaling functions and wavelets than they are to the original conjugate mirror filters  $h$  and  $g$ . This explains why wavelets provide appropriate models for understanding the applications of these filter banks. Chapter 8 relates more general filter banks to wavelet packet bases.

## Perfect reconstruction FB

- **Theorem 7.7 (Vetterli)** The FB performs an exact reconstruction for any input signal iif

$$\begin{aligned} \hat{h}^*(\omega)\hat{\tilde{h}}(\omega) + \hat{g}^*(\omega)\hat{\tilde{g}}(\omega) &= 2 \\ \hat{h}^*(\omega + \pi)\hat{\tilde{h}}(\omega) + \hat{g}^*(\omega + \pi)\hat{\tilde{g}}(\omega) &= 0 \end{aligned} \quad (\textit{alias free})$$

Matrix notations

$$\begin{pmatrix} \hat{h}^*(\omega) \\ \hat{g}^*(\omega) \end{pmatrix} = \frac{2}{\Delta(\omega)} \begin{pmatrix} \hat{g}(\omega + \pi) \\ -\hat{h}(\omega + \pi) \end{pmatrix}$$
$$\Delta(\omega) = \hat{h}(\omega)\hat{g}(\omega + \pi) - \hat{h}(\omega + \pi)\hat{g}(\omega)$$

When all the filters are FIR, the determinant can be evaluated, which yields simpler relations between the decomposition and the reconstruction filters.

## Changing the sampling rate

- Downsampling

$$\hat{y}(2\omega) = \frac{1}{2}(\hat{x}(\omega) + \hat{x}(\omega + \pi)) = \sum_{n=-\infty}^{+\infty} x[2n]e^{-jn\omega}$$

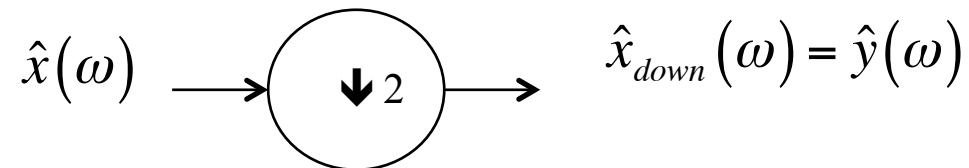

$$\hat{y}(\omega) = \frac{1}{2} \left( \hat{x}\left(\frac{\omega}{2}\right) + \hat{x}\left(\frac{\omega}{2} + \pi\right) \right)$$

- Upsampling

$$\hat{y}(\omega) = \hat{x}(2\omega) = \sum_{n=-\infty}^{+\infty} x[n]e^{-j2n\omega}$$

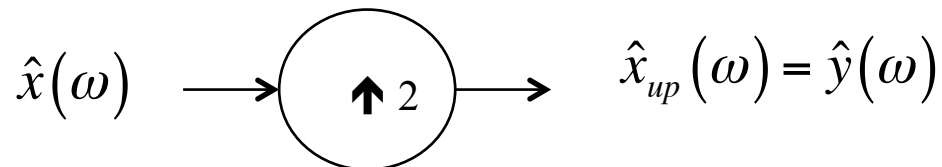

## Subsampling: proof

$$\begin{aligned}\hat{y}(\omega) &= \dots y[0] + y[1]e^{-j\omega} + y[2]e^{-j2\omega} + \dots = \\ &= \dots x[0] + x[2]e^{-j\omega} + x[4]e^{-j2\omega} + \dots \rightarrow\end{aligned}$$

*thus*

$$\hat{y}(2\omega) = \dots x[0] + x[2]e^{-j2\omega} + x[4]e^{-j4\omega} + \dots$$

*but*

$$x[1]e^{-j\omega} + x[1]e^{-j(\omega+\pi)} = 0 \rightarrow \frac{1}{2}(x[1]e^{-j\omega} + x[1]e^{-j(\omega+\pi)}) = 0$$

$$x[2]e^{-j2\omega} = \frac{1}{2}(x[2]e^{-j2\omega} + x[2]e^{-j2(\omega+\pi)})$$

*thus*

$$\hat{y}(2\omega) = \dots x[0] + \frac{1}{2}(x[1]e^{-j\omega} + x[1]e^{-j(\omega+\pi)}) + \frac{1}{2}(x[2]e^{-j2\omega} + x[2]e^{-j2(\omega+\pi)}) + \dots =$$

$$\hat{y}(2\omega) = \frac{1}{2}(\hat{x}(\omega) + \hat{x}(\omega + \pi))$$

## Perfect Reconstruction conditions

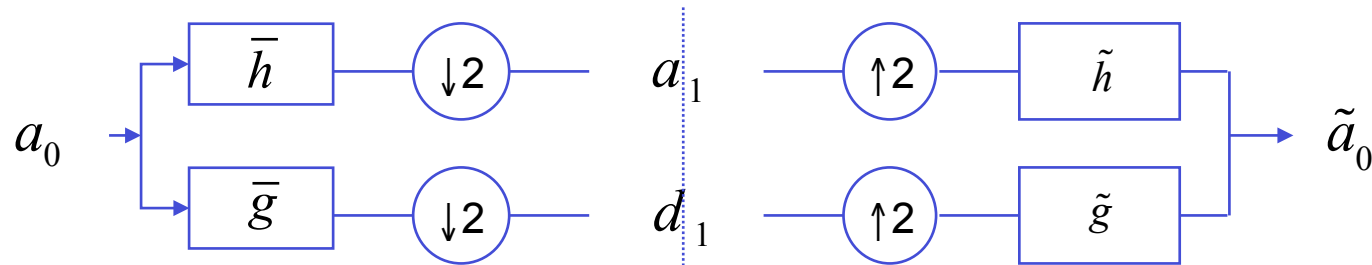

$$a_1(2\omega) = \frac{1}{2} \left( a_0(\omega) \hat{h}(\omega) + a_0(\omega + \pi) \hat{h}(\omega + \pi) \right)$$

since  $h$  and  $g$  are real

$$h[n] \rightarrow h(\omega)$$

$$h[-n] = \bar{h}[n] \rightarrow \hat{h}(\omega) = \hat{h}(-\omega) = h^*(\omega)$$

thus, replacing in the first equation

$$a_1(2\omega) = \frac{1}{2} \left( a_0(\omega) \hat{h}^*(\omega) + a_0(\omega + \pi) \hat{h}^*(\omega + \pi) \right)$$

Similarly, for the high-pass branch

$$d_1(2\omega) = \frac{1}{2} \left( a_0(\omega) \hat{g}^*(\omega) + a_0(\omega + \pi) \hat{g}^*(\omega + \pi) \right)$$

$$\hat{a}_0(\omega) = \hat{a}_1(2\omega) \hat{h}(\omega) + \hat{d}_1(2\omega) \hat{g}(\omega)$$



## Perfect Reconstruction conditions

- Putting all together

$$\begin{aligned}
 \hat{\tilde{a}}_0(\omega) &= \hat{a}_1(2\omega)\hat{\tilde{h}}(\omega) + \hat{d}_1(2\omega)\hat{\tilde{g}}(\omega) = \\
 &= \frac{1}{2} \left( a_0(\omega)\hat{h}^*(\omega) + a_0(\omega+\pi)\hat{h}^*(\omega+\pi) \right) \hat{\tilde{h}}(\omega) \\
 &\quad + \frac{1}{2} \left( a_0(\omega)\hat{g}^*(\omega) + a_0(\omega+\pi)\hat{g}^*(\omega+\pi) \right) \hat{\tilde{g}}(\omega) \\
 \hat{\tilde{a}}_0(\omega) &= \frac{1}{2} \left( \hat{h}^*(\omega)\hat{\tilde{h}}(\omega) + \hat{g}^*(\omega)\hat{\tilde{g}}(\omega) \right) a_0(\omega) + \frac{1}{2} \left( \hat{h}^*(\omega+\pi)\hat{\tilde{h}}(\omega) + \hat{g}^*(\omega+\pi)\hat{\tilde{g}}(\omega) \right) a_0(\omega+\pi) \\
 &\qquad\qquad\qquad = 1 \qquad\qquad\qquad\qquad\qquad\qquad\qquad\qquad\qquad\qquad\qquad = 0 \quad (\text{alias-free})
 \end{aligned}$$

$$\begin{aligned}
 \hat{h}^*(\omega)\hat{\tilde{h}}(\omega) + \hat{g}^*(\omega)\hat{\tilde{g}}(\omega) &= 2 \\
 \hat{h}^*(\omega+\pi)\hat{\tilde{h}}(\omega) + \hat{g}^*(\omega+\pi)\hat{\tilde{g}}(\omega) &= 0
 \end{aligned}$$

(alias free)

Matrix notations

$$\begin{pmatrix} \hat{\tilde{h}}^*(\omega) \\ \hat{\tilde{g}}^*(\omega) \end{pmatrix} = \frac{2}{\Delta(\omega)} \begin{pmatrix} \hat{g}(\omega+\pi) \\ -\hat{h}(\omega+\pi) \end{pmatrix}$$

$$\Delta(\omega) = \hat{h}(\omega)\hat{g}(\omega+\pi) - \hat{h}(\omega+\pi)\hat{g}(\omega)$$

## Perfect reconstruction biorhogonal filters

- Theorem 7.8. Perfect reconstruction filters also satisfy

$$\hat{h}^*(\omega)\tilde{h}(\omega) + \hat{h}^*(\omega + \pi)\tilde{h}(\omega + \pi) = 2$$

Furthermore, if the filters have a finite impulse response there exists  $a$  in  $R$  and  $l$  in  $Z$  such that

$$\begin{aligned} \hat{g}(\omega) &= ae^{-i(2l+1)\omega}\tilde{h}^*(\omega + \pi) \\ \tilde{\hat{g}}(\omega) &= \frac{1}{a}e^{-i(2l+1)\omega}\hat{h}^*(\omega + \pi) \end{aligned} \quad \Rightarrow \quad a=1, l=0 \quad \Rightarrow$$

$$\begin{aligned} \hat{g}(\omega) &= e^{-j\omega}\tilde{h}^*(\omega + \pi) \\ \tilde{\hat{g}}(\omega) &= e^{-j\omega}\hat{h}^*(\omega + \pi) \end{aligned}$$

Correspondingly

$$\begin{aligned} g[n] &= (-1)^{1-n}\tilde{h}[1-n] \\ \tilde{g}[n] &= (-1)^{1-n}h[1-n] \end{aligned}$$

- Conjugate Mirror Filters:

$$\tilde{h} = h \rightarrow \left| \hat{h}(\omega) \right|^2 + \left| \hat{h}(\omega + \pi) \right|^2 = 2$$

## Perfect reconstruction biorthogonal filters qui

Given  $h$  and  $\tilde{h}$  and setting  $a=1$  and  $l=0$  in (2) the remaining filters are given by the following relations

$$(3) \quad \begin{aligned} \hat{g}(\omega) &= e^{-i\omega} \hat{h}^*(\omega + \pi) \\ \tilde{g}(\omega) &= e^{-i\omega} \tilde{h}^*(\omega + \pi) \end{aligned}$$

- The filters  $h$  and  $\tilde{h}$  are related to the scaling functions  $\phi$  and  $\tilde{\phi}$  via the corresponding two-scale relations, as was the case for the orthogonal filters (see eq. 1).

Switching to the  $z$ -domain

$$\begin{aligned} g(z) &= z^{-1} \tilde{h}(-z^{-1}) \\ \tilde{g}(z) &= z^{-1} h(-z^{-1}) \end{aligned}$$

Signal domain

$$\begin{aligned} g[n] &= (-1)^{1-n} \tilde{h}[1-n] \\ \tilde{g}[n] &= (-1)^{1-n} h[1-n] \end{aligned}$$

## Biorthogonal filter banks

- A 2-channel **multirate** filter bank convolves a signal  $a_0$  with

a low pass filter

$$\bar{h}[n] = h[-n]$$

and a high pass filter

$$\bar{g}[n] = g[-n]$$

and sub-samples the output by 2

$$a_1[n] = a_0 * \bar{h}[2n]$$

$$d_1[n] = a_0 * \bar{g}[2n]$$

A reconstructed signal  $\tilde{a}_0$  is obtained by filtering the zero-expanded signals with a *dual low-pass*  $\tilde{h}[n]$  and *high pass filter*  $\tilde{g}[n]$

$$\tilde{a}_0[n] = \tilde{a}_1 * \tilde{h}[n] + \tilde{d}_1 * \tilde{g}[n]$$
$$y[n] = \tilde{x}[n] = \begin{cases} x[p] & n = 2p \\ 0 & n = 2p + 1 \end{cases}$$

Imposing the PR condition (output signal=input signal) one gets the relations that the different filters must satisfy (Theorem 7.7)

## Revisiting the orthogonal case (CMF)

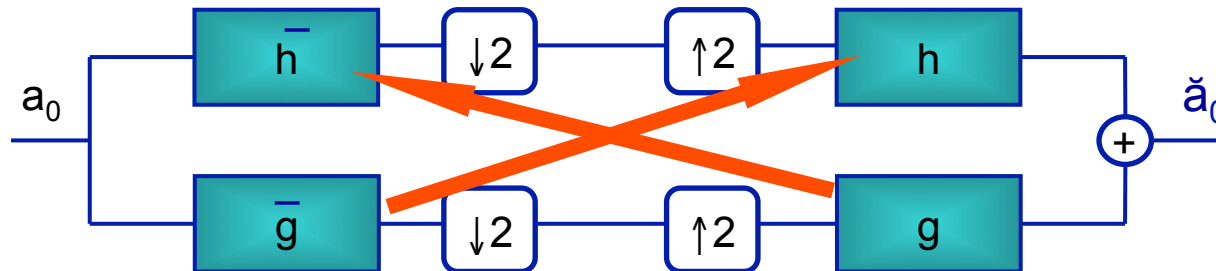

Taking  $\bar{h}[n] = h[-n]$  as reference (which amounts to choosing the analysis low-pass filter) the following relations hold for an orthogonal filter bank:

$\bar{h}[n] = h[-n] \Leftrightarrow h[n] = \bar{h}[-n]$       synthesis low-pass (interpolation) filter:  
reverse the order of the coefficients

$g[n] = (-1)^{1-n} h[1-n]$       negate every other sample

## Orthogonal vs biorthogonal PRFB

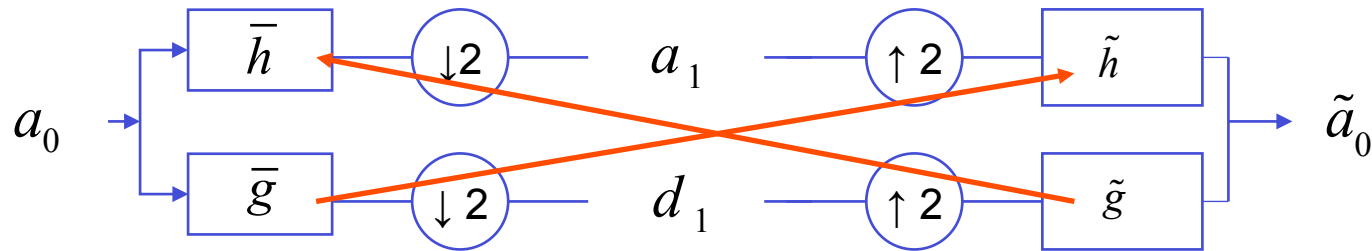

$\tilde{h} \neq h$  Biorthogonal PRFB

$$\hat{h}^*(\omega)\tilde{h}(\omega) + \hat{h}^*(\omega + \pi)\tilde{h}(\omega + \pi) = 2$$

$$\hat{g}(\omega) = e^{-j\omega}\tilde{h}^*(\omega + \pi)$$

$$\tilde{g}(\omega) = e^{-j\omega}h^*(\omega + \pi)$$

In the signal domain

$$g[n] = (-1)^{1-n}\tilde{h}[1-n]$$

$$\tilde{g}[n] = (-1)^{1-n}h[1-n]$$

$\tilde{h} = h$  Orthogonal PRFB

$$|\hat{h}(\omega)|^2 + |\hat{h}(\omega + \pi)|^2 = 2$$

$$\tilde{g} = g$$

# Fast BWT

- Two different sets of basis functions are used for analysis and synthesis

$$a_{j+1}[n] = a_j * \bar{h}[2n]$$

$$d_{j+1}[n] = a_j * \bar{g}[2n]$$

$$a_j[n] = \tilde{a}_{j+1} * \tilde{h}[n] + \tilde{d}_{j+1} * \tilde{g}[n]$$

- PR filterbank

$$g[n] = (-1)^{1-n} \tilde{h}[1-n]$$

$$\tilde{g}[n] = (-1)^{1-n} h[1-n]$$

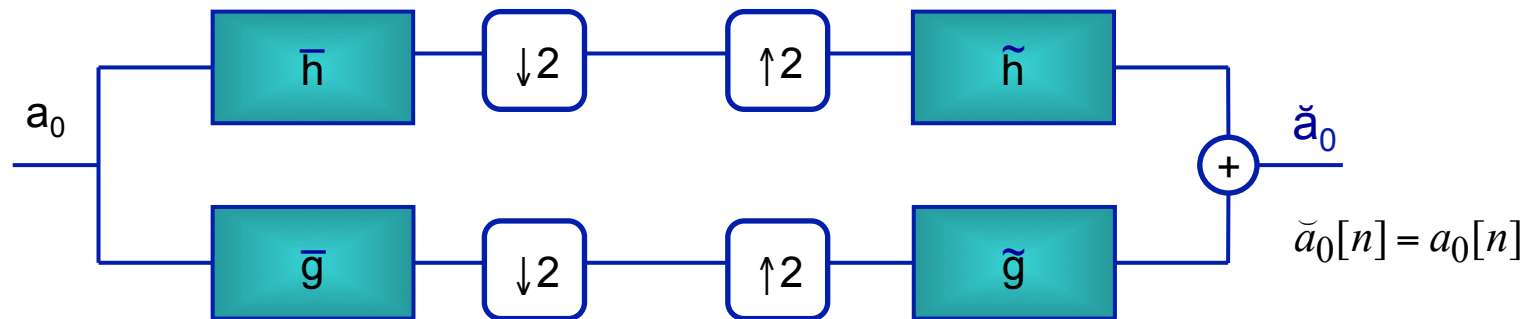

## Be careful with notations!

- In the simplified notation where
  - $h[n]$  is the analysis low pass filter and  $g[n]$  is the analysis band pass filter, as it is the case in most of the literature;
  - the delay factor is not made explicit;
- The relations among the filters modify as follows

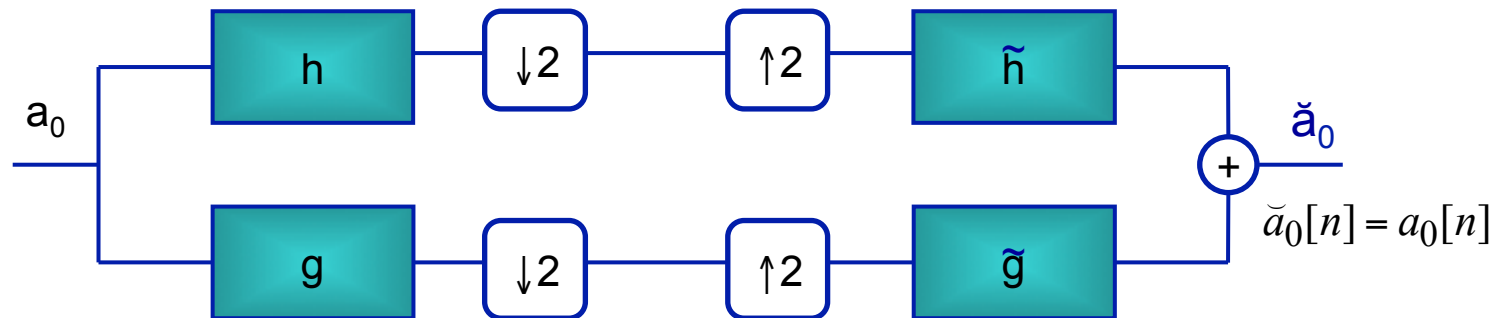

$$g[n] = (-1)^{-n} \tilde{h}[n]$$

$$\tilde{g}[n] = (-1)^{-n} h[n]$$

Slightly different formulation: the high pass filters are obtained by the low pass filters by negating the odd terms



# Biorthogonal bases

## Orthonormal basis

$\{e_n\}_{n \in \mathbb{N}}$ : basis of Hilbert space

Orthogonality condition  $\langle e_n, e_p \rangle = 0 \quad \forall n \neq p$

$\forall y \in H,$

There exists a sequence

$$\lambda[n] = \langle y, e_n \rangle : \\ y = \sum_n \lambda[n] e_n$$

$|e_n|^2 = 1$       ortho-normal basis

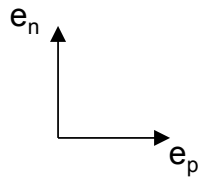

## Bi-orthogonal basis

$\{e_n\}_{n \in \mathbb{N}}$ : linearly independent

$\forall y \in H, \quad \exists A > 0$  and  $B > 0 :$

$$\lambda[n] = \langle y, e_n \rangle : \\ y = \sum_n \lambda[n] \tilde{e}_n \\ \frac{|y|^2}{B} \leq \sum_n |\lambda[n]|^2 \leq \frac{|y|^2}{A}$$

Biorthogonality condition:

$$\langle e_n, \tilde{e}_p \rangle = \delta[n - p] \\ y = \sum_n \langle f, \tilde{e}_n \rangle e_n = \sum_n \langle f, e_n \rangle \tilde{e}_n$$

$A=B=1 \Rightarrow$  orthogonal basis

## Biorthogonal bases

If  $h$  and  $\tilde{h}$  are FIR

$$\hat{\Phi}(\omega) = \prod_{p=1}^{+\infty} \frac{\hat{h}(2^{-p}\omega)}{\sqrt{2}} \hat{\Phi}(0), \quad \hat{\tilde{\Phi}}(\omega) = \prod_{p=1}^{+\infty} \frac{\hat{h}(2^{-p}\omega)}{\sqrt{2}} \hat{\tilde{\Phi}}(0)$$

Though, some other conditions must be imposed to guarantee that  $\varphi^\wedge$  and  $\varphi^\wedge\tilde{}$  are FT of finite energy functions. The theorem from Cohen, Daubechies and Feaveau provides *sufficient* conditions (Theorem 7.10 in M1999 and Theorem 7.13 in M2009)

The functions  $\hat{\phi}$  and  $\hat{\tilde{\phi}}$  satisfy the biorthogonality relation

$$\langle \varphi(t), \tilde{\varphi}(t-n) \rangle = \delta[n]$$

The two wavelet families  $\left\{ \psi_{j,n} \right\}_{(j,n) \in \mathbb{Z}^2}$  and  $\left\{ \tilde{\psi}_{j,n} \right\}_{(j,n) \in \mathbb{Z}^2}$  are Riesz bases of  $L^2(\mathbb{R})$

$$\langle \psi_{j,n}, \tilde{\psi}_{j',n'} \rangle = \delta[n-n'] \delta[j-j']$$

Any  $f \in L^2(\mathbb{R})$  has two possible decompositions in these bases

$$f = \sum_{n,j} \langle f, \psi_{j,n} \rangle \tilde{\psi}_{j,n} = \sum_{n,j} \langle f, \tilde{\psi}_{j,n} \rangle \psi_{j,n}$$

## Reminder

**Theorem 7.13.** If  $h$ ,  $g$ ,  $\tilde{h}$ , and  $\tilde{g}$  are perfect reconstruction filters, and their Fourier transforms are bounded, then  $\{\tilde{h}[n - 2l], \tilde{g}[n - 2l]\}_{l \in \mathbb{Z}}$  and  $\{h[n - 2l], g[n - 2l]\}_{l \in \mathbb{Z}}$  are biorthogonal Riesz bases of  $\ell^2(\mathbb{Z})$ .

## Summary of Biorthogonality relations

- An infinite cascade of PR filter banks  $(h, g), (\tilde{h}, \tilde{g})$  yields two scaling functions and two wavelets whose Fourier transform satisfy

$$\hat{\Phi}(2\omega) = \frac{1}{\sqrt{2}} \hat{h}(\omega) \hat{\Phi}(\omega) \quad \Leftrightarrow \quad \varphi\left(\frac{t}{2}\right) = \sum_{n=-\infty}^{+\infty} h[n] \varphi(t-n) \quad (i)$$

$$\hat{\tilde{\Phi}}(2\omega) = \frac{1}{\sqrt{2}} \hat{\tilde{h}}(\omega) \hat{\tilde{\Phi}}(\omega) \quad \Leftrightarrow \quad \tilde{\varphi}\left(\frac{t}{2}\right) = \sum_{n=-\infty}^{+\infty} \tilde{h}[n] \tilde{\varphi}(t-n) \quad (ii)$$

$$\hat{\Psi}(2\omega) = \frac{1}{\sqrt{2}} \hat{g}(\omega) \hat{\Phi}(\omega) \quad \Leftrightarrow \quad \psi\left(\frac{t}{2}\right) = \sum_{n=-\infty}^{+\infty} g[n] \varphi(t-n) \quad (iii)$$

$$\hat{\tilde{\Psi}}(2\omega) = \frac{1}{\sqrt{2}} \hat{\tilde{g}}(\omega) \hat{\tilde{\Phi}}(\omega) \quad \Leftrightarrow \quad \tilde{\psi}\left(\frac{t}{2}\right) = \sum_{n=-\infty}^{+\infty} \tilde{g}[n] \tilde{\varphi}(t-n) \quad (iv)$$

# Properties of biorthogonal filters

Imposing the zero average condition to  $\psi$  in equations (iii) and (iv)

$$\hat{\Psi}(0) = \hat{\tilde{\Psi}}(0) = 0 \rightarrow \hat{g}(0) = \hat{\tilde{g}}(0) = 0$$

replacing into the relations (3) (also shown below)

$$\hat{g}(\omega) = e^{-i\omega} \hat{h}^*(\omega + \pi) \quad \hat{\tilde{g}}(\omega) = e^{-i\omega} \hat{\tilde{h}}^*(\omega + \pi) \rightarrow \hat{h}^*(\pi) = \hat{\tilde{h}}(\pi) = 0$$

Furthermore, replacing such values in the PR condition (1)

$$\hat{h}^*(\omega) \hat{h}(\omega) + \hat{g}^*(\omega) \hat{\tilde{g}}(\omega) = 2 \rightarrow \hat{h}^*(0) \hat{h}(0) = 2$$

It is common choice to set

$$\hat{h}^*(0) = \hat{h}(0) = \sqrt{2}$$

# Biorthogonal bases

- If the decomposition and reconstruction filters are different, the resulting bases is non-orthogonal
- The cascade of J levels is equivalent to a signal decomposition over a non-orthogonal basis

$$\left[ \left\{ \varphi_J [k - 2^J n] \right\}_{n \in \mathbb{Z}}, \left\{ \psi_j [k - 2^j n] \right\}_{1 \leq j \leq J, n \in \mathbb{Z}} \right]$$

- The dual bases is needed for reconstruction

# Example: bior3.5

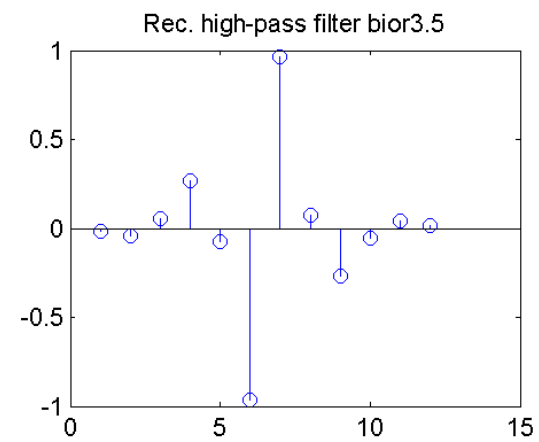
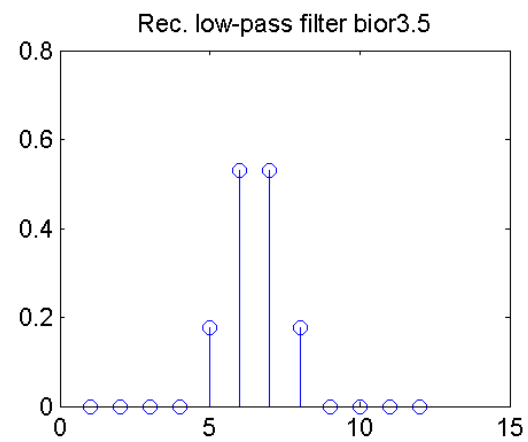
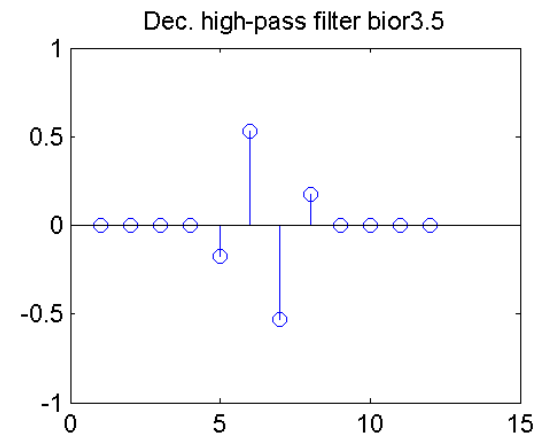
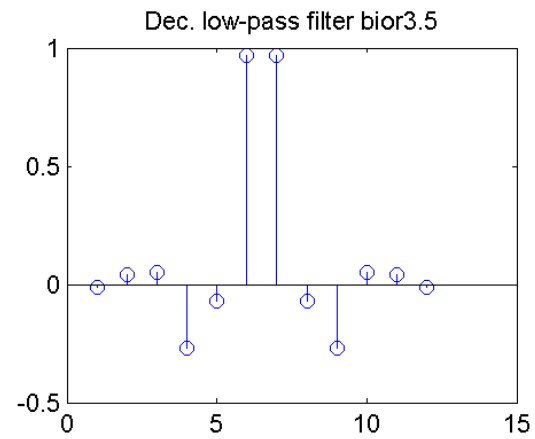

# Example: bior3.5

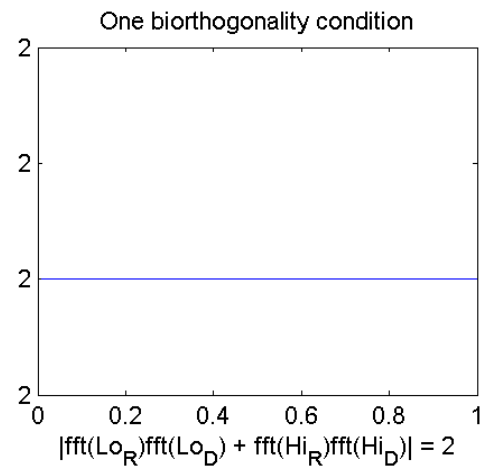
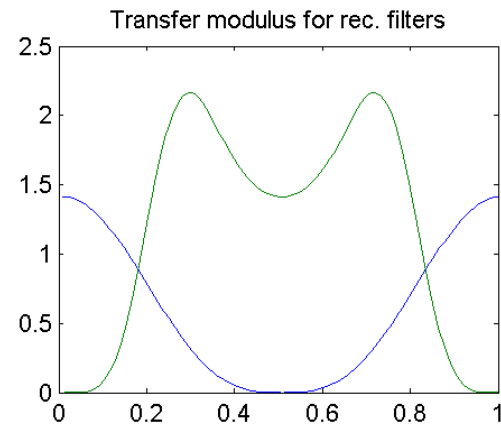
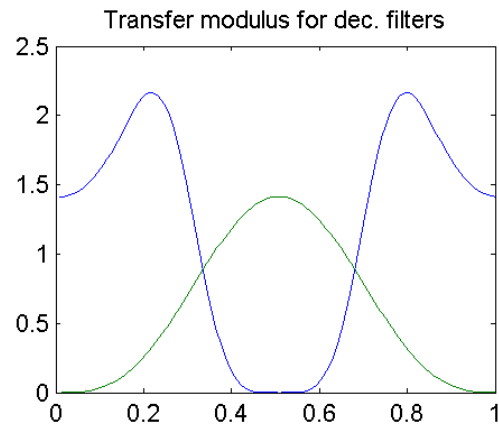



# Biorthogonal bases

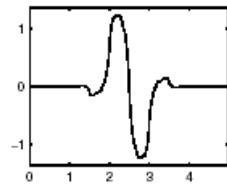

bior1.3

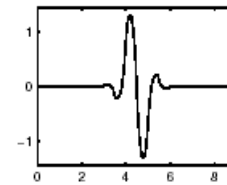
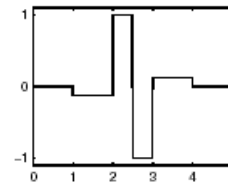

bior1.5

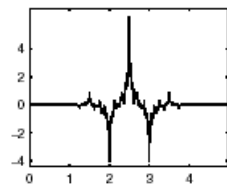
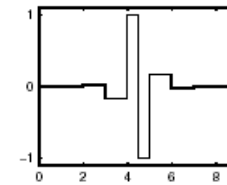

bior2.2

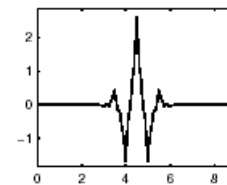
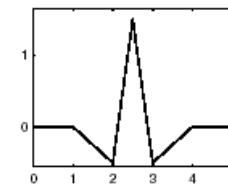

bior2.4

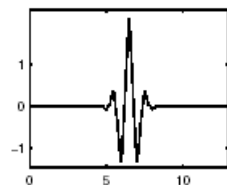
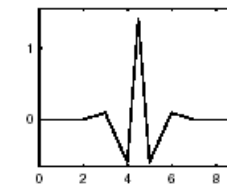

bior2.6

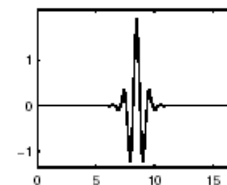
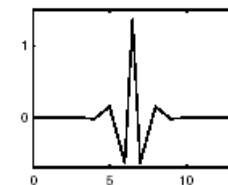

bior2.8

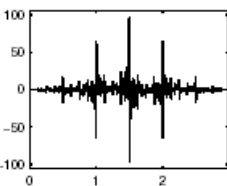
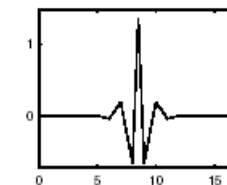

bior3.1

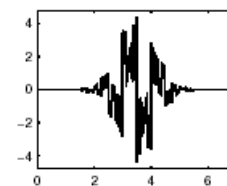
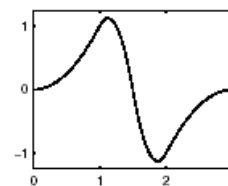

bior3.3

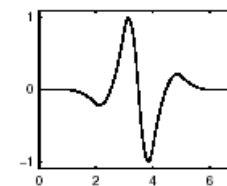

# Biorthogonal bases

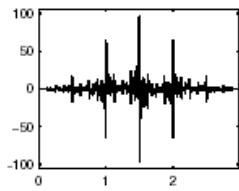

bior3.1

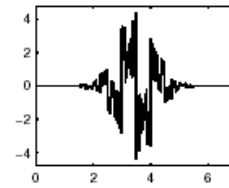
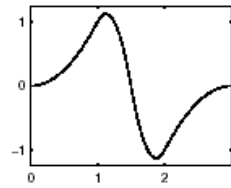

bior3.3

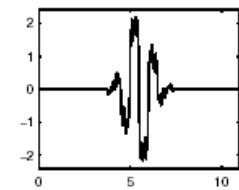
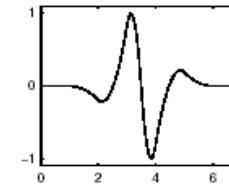

bior3.5

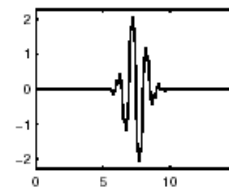
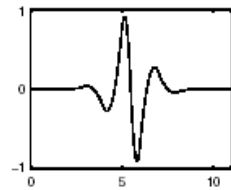

bior3.7

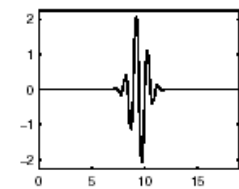
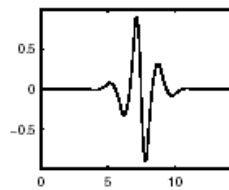

bior3.9

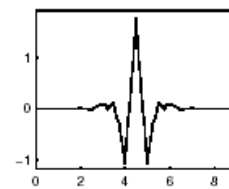
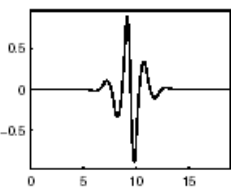

bior4.4

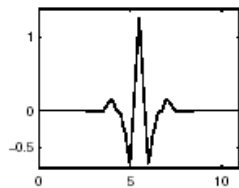
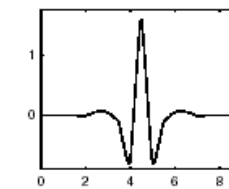

bior5.5

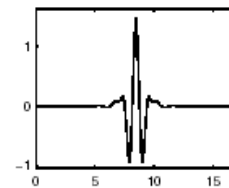
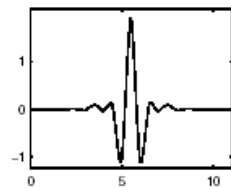

bior6.8

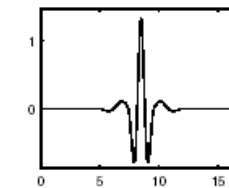

## CMF : orthogonal filters

- PR filter banks decompose the signals in a basis of  $l^2(\mathbb{Z})$ . This basis is *orthogonal* for *Conjugate Mirror Filters* (CMF).
- [Smith&Barnwell,1984]: Necessary and sufficient condition for PR *orthogonal FIR* filter banks, called CMFs
  - Imposing that *the decomposition filter h is equal to the reconstruction filter h<sup>-</sup>*, eq. (1) becomes

$$\hat{h}^*(\omega)\hat{\tilde{h}}(\omega) + \hat{h}^*(\omega + \pi)\hat{\tilde{h}}(\omega + \pi) = 2 \quad (1) \rightarrow$$

$$\hat{h}^*(\omega)\hat{h}(\omega) + \hat{h}^*(\omega + \pi)\hat{h}(\omega + \pi) = 2 \rightarrow$$

$$|\hat{h}(\omega)|^2 + |\hat{h}(\omega + \pi)|^2 = 2$$

- Correspondingly

$$\tilde{h}[n] = h[n]$$

$$\tilde{g}[n] = g[n] = (-1)^{1-n} h[1-n]$$

# Summary

- PR filter banks decompose the signals in a basis of  $l^2(Z)$ . This basis is *orthogonal* for *Conjugate Mirror Filters* (CMF).
- [Smith&Barnwell,1984]: Necessary and sufficient condition for PR **orthogonal FIR** filter banks, called **CMFs**
  - Imposing that the decomposition filter  $h$  is equal to the reconstruction filter  $\tilde{h}$ , eq. (1) becomes

$$\hat{h}^*(\omega)\hat{\tilde{h}}(\omega) + \hat{h}^*(\omega + \pi)\hat{\tilde{h}}(\omega + \pi) = 2 \rightarrow$$

$$\hat{h}^*(\omega)\hat{h}(\omega) + \hat{h}^*(\omega + \pi)\hat{h}(\omega + \pi) = 2 \rightarrow$$

- Correspondingly  $|\hat{h}(\omega)|^2 + |\hat{h}(\omega + \pi)|^2 = 2$

$$\tilde{h}[n] = h[n]$$

$$\tilde{g}[n] = g[n] = (-1)^{1-n} h[1-n]$$

# Properties

- **Support**
  - $h, \tilde{h}$  are FIR  $\rightarrow$  scaling functions and wavelets have compact support
- **Vanishing moments**
  - The number of vanishing moments of  $\Psi$  is equal to the order  $\tilde{p}$  of zeros of  $\tilde{h}$  in  $\pi$ . Similarly, the number of vanishing moments of  $\tilde{\psi}$  is equal to the order  $p$  of zeros of  $h$  in  $\pi$ .
- **Regularity**
  - One can show that the regularity of  $\Psi$  and  $\phi$  increases with the number of vanishing moments of  $\tilde{\psi}$ , thus with the order  $p$  of zeros of  $h$  in  $\pi$ .
  - Viceversa, the regularity of  $\tilde{\psi}$  and  $\tilde{\phi}$  increases with the number of vanishing moments of  $\Psi$ , thus with the order  $\tilde{p}$  of zeros of  $\tilde{h}$  in  $\pi$ .
- **Symmetry**
  - It is possible to construct both symmetric and anti-symmetric bases using linear phase filters
    - In the orthogonal case only the Haar filter is possible as FIR solution.